

The CarboProbe HT is suitable for use at temperatures between 600°C to 1700°C. It is most often used to control % of oxygen within a treatment cycle, typically in the range 0.5% to 5% (but can work up to 21%). For the measurement of oxygen in carburising mixtures, please consult us for a more suitable model.

All of the components exposed to high temperature gases are ceramic or platinum, for optimum corrosion resistance. It is of robust construction, with an alumina ceramic sheath to protect the sensing element.

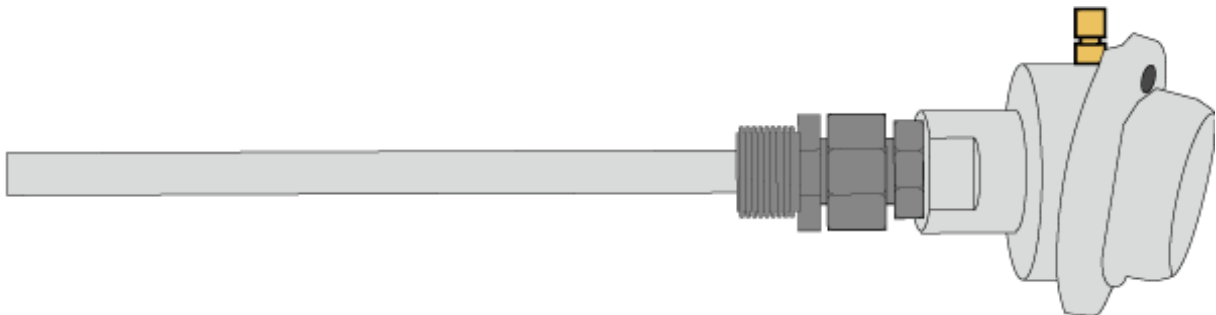

Key feature

- **Very high temperatures up to 1700°C**
- **Suitable for ceramic kilns, industrial furnaces and incinerators**
- **Can be used to obtain efficient combustion in a kiln**
- **Can also be used to control reduction in a kiln**
- CarboProbe HT is the latest generation of in-situ oxygen sensors for ideal temperatures of up to 1700°C
- The probe can be installed anywhere in the kiln or furnace
- The probe can be used at any orientation for temperatures up to 1100 °C, but should be placed vertically at high temperatures
- Every probe is 100% tested with certification, certificates are enclosed with each probe
- High performance, low cost sensor
- Response time < 1.0 second
- The CarboProbe HT can be used in a closed-loop control system to regulate the air or fuel supply

Specifications

Output	0 to 1100 mV DC over operating range
Readout impedance	This probe should be used with controlling, recording and indicating instruments having input impedance of 8megohms or higher.
Accuracy	±2 mV in normal operating range
Response time	Less than 1.0 second
Thermocouple	Type R
Operating Temperatures	600°C to 1700°C
Mechanical shock	Resists mild mechanical shock. Handle carefully
Reference air	Uncontaminated dry air at maximum rate of 0.5 - 1 l/h
Immersion depth	5 cm minimum

